



**SERMAX**<sup>®</sup>  
S C A L E S

Weighing Solutions

**LMB** . Series

**L**inear **M**odular **B**elt weighers for sticky and fragile products.

[www.sermaxscales.com](http://www.sermaxscales.com)

## LMB 1 - 6 LINES

- Linear weigher with modular belts.
- Designed for all type of products.
- Up to a Ø30mm of size per single piece of product.
- Specially designed for sticky and fragile products.

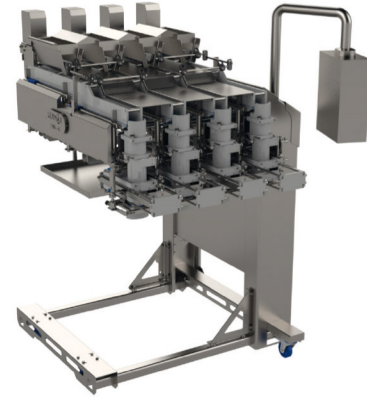

## TECHNICAL DETAILS

| Max. piece size   | Nominal Weight | Production   | Acuracy             |
|-------------------|----------------|--------------|---------------------|
| Ø 30 mm           | 10- 200 Gr     | 10 - 60 dpm  | + 1 Piece           |
| Volume Oof Bucket | N. of Heads    | N. of Levels | Infeed Chute Volume |
| 0.25 / 0.5 L      | 1 - 6          | 2 - 3        | 25 L                |

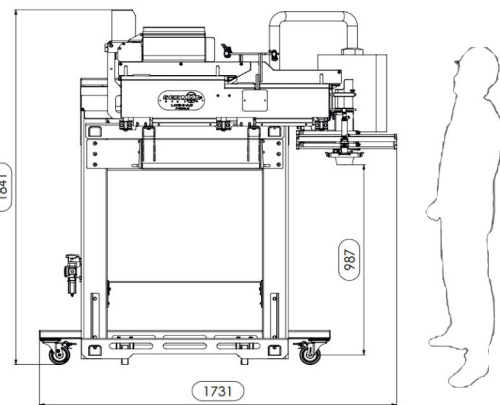

## FEATURES

Higienic Design  
FDA Components  
Easy to clean



Mobile Support  
Easy to operate  
Direct tray filling

## TYPICAL APPLICATIONS



LMB + STEPPER CONVEYOR



LMB + 4 X 1 CONVEYOR



3 PRODUCTS MIX + 3 LMB

## AUXILIARY EQUIPMENTS



FEET TO POINT SERVO BELT

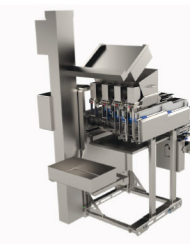

COLUMN ELEVATOR



4 X 1 CONVEYOR



OVERWEIGHT REJECT DEVICE

## PACKAGING



Other packages under request.





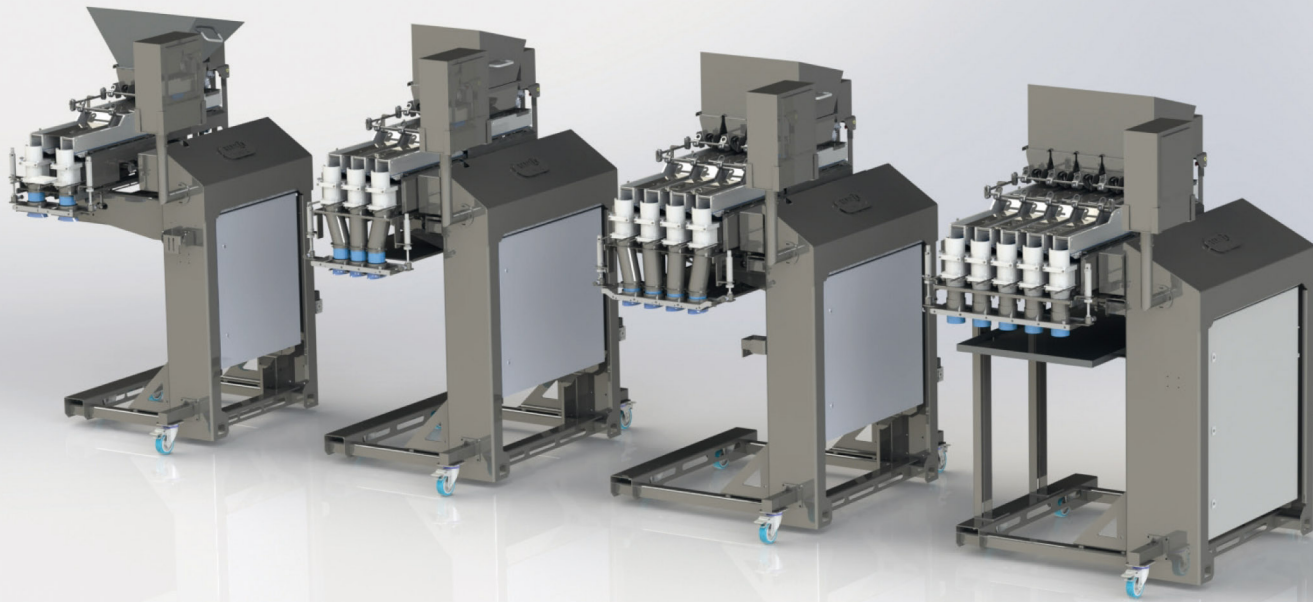

Exclusive weighing solutions

Send us your product to test at :

C/ Thomas Alva Edison, 67  
Pol. Ind. Plans D'Arau  
08787 La Pobla de Claramunt (Bcn)

+34 93 184 7240

[Info@sermaxscales.com](mailto:Info@sermaxscales.com)

[www.sermaxscales.com](http://www.sermaxscales.com)